

TopTip

POB 103 CH-6830 Chiasso (Switzerland)
tel. +41-91-6900 333 fax +41-91-6900 335
email: toptip@gmx.net www.toptip-swiss.com

Press-tip

Precision 4 stroke press

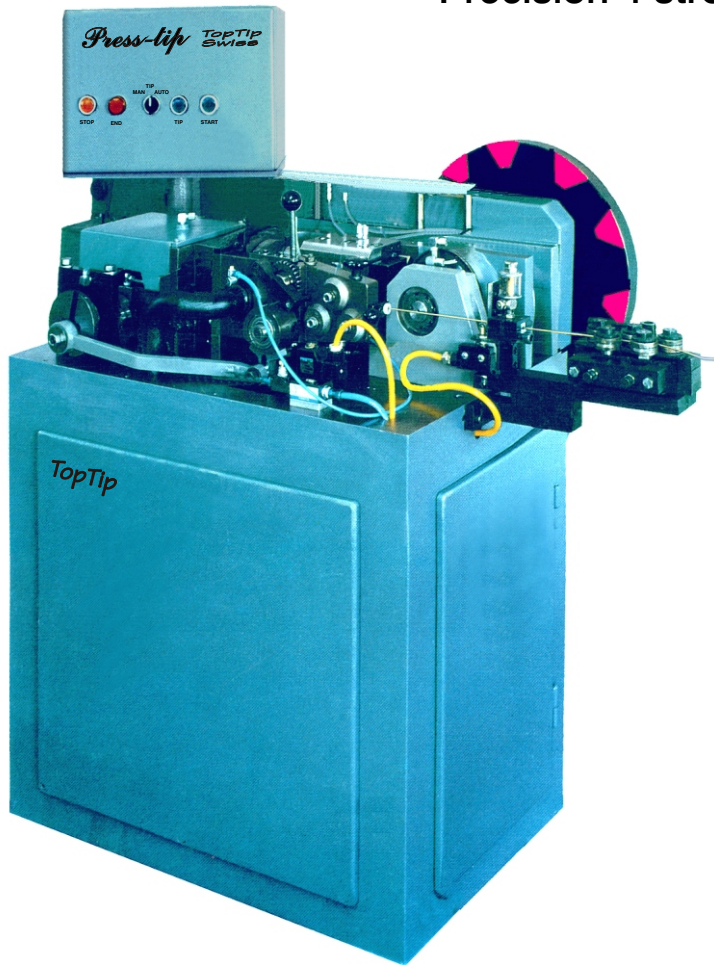

If you need to produce any small part out of a wire at a really economical way this Swiss made press is the solution for you.

Following items may be easily and quickly manufactured with this machine:

- ▶ blanks for ball pen tips
- ▶ contacts
- ▶ rivets
- ▶ many special shapes

in any of the following materials:

- ▶ brass
- ▶ copper
- ▶ aluminium
- ▶ nickel-silver
- ▶ steel

You will get your product at an impressive speed at the highest possible quality.

Your product will be obtained from a wire by a cold pressing operation in up to 4 successive strokes for maximum accuracy and limiting in this way the consumption of the dies to a minimum.

This can be achieved only because all parts of the machine subject to friction are made out of hardened ground steel with tightest tolerances and with centralized lubrication. Tungsten carbide is used for dies and pins, thus guaranteeing a long life at a constant quality.

The wire is straightened, cut in small bits, formed and ejected in one cycle, so that you will obtain the possible highest production speed.

The machine performs immediate start and stop operations and the well studied safety system corresponds to European standards.

Main Characteristics:

Production speed: up to 600 pcs/min
Wire size Ø 3 mm max
Cutting length: 15 ÷ 20 mm
Voltage: 220/380 V - 50 Hz
Weight: ~750 Kg
Overall sizes: 120 (l) x 80 (w) x 150 (h) cm

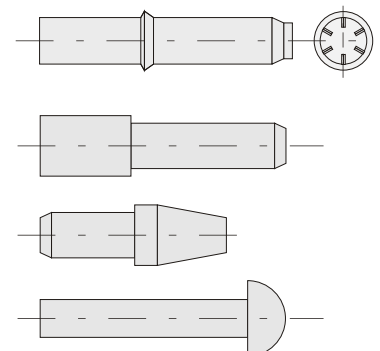

Some parts which can be produced with *Press-tip*:

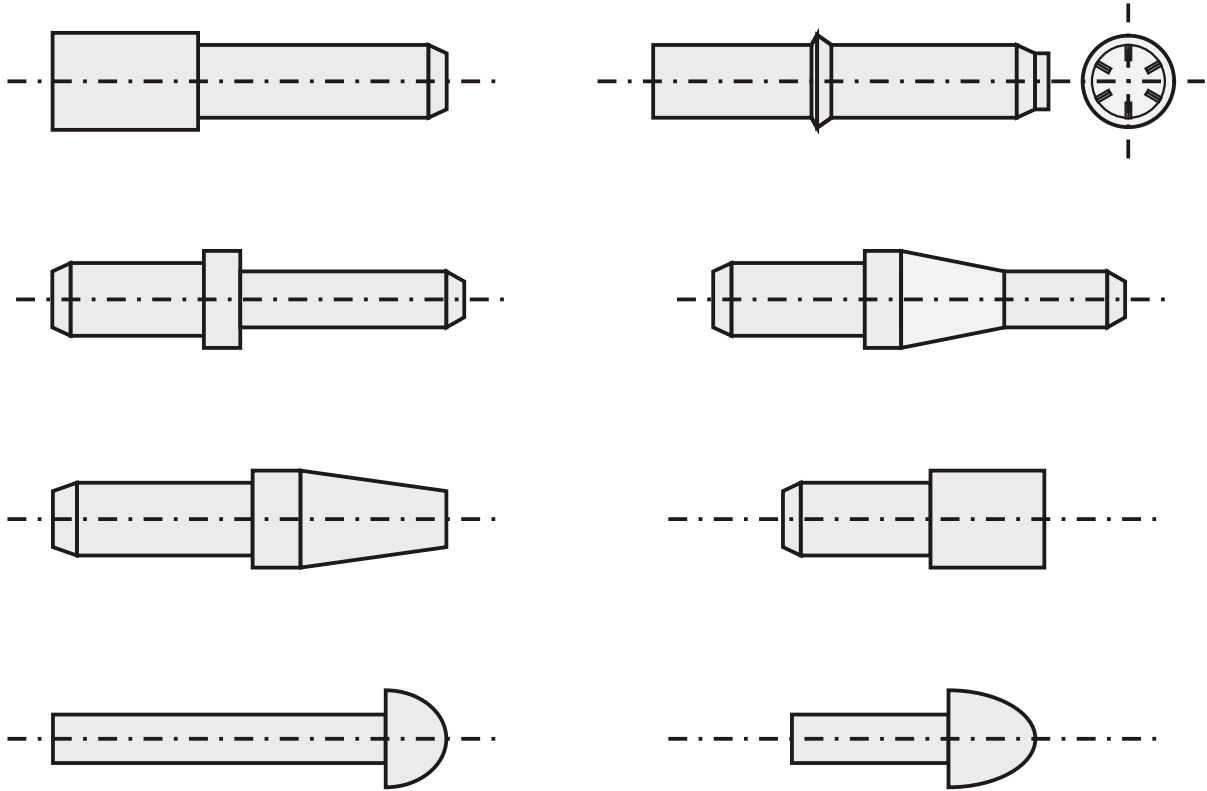

Please send us your drawing and we will check if it is possible to produce it with *Press-tip*.

